



SED-902 Remote-Master Installation Guide Wiegand & Gallagher (Cardax) System

February 2025

**WARNING: PLEASE READ THIS GUIDE PRIOR TO ATTEMPTING
THE INSTALLATION OF THE SED-902 SYSTEM**

PRODUCT WARRANTY

This product is covered by a 12 month, back to base warranty from date of purchase, and proof of purchase should be supplied. The warranty does not cover damage that has resulted from the improper installation or improper use of this product. The warranty does not cover lightning damage, product misuse, electrical surges or acts of God.

LIMITATION OF LIABILITY

Sec.Eng Systems Pty Ltd does not accept any liability for the loss or damage to property or persons in relation to goods supplied. This disclaimer is only limited to the warranty of the goods supplied and the intended use.

NOTE: THIS MANUAL IS SUBJECT TO COPYRIGHT

SEC-ENG SYSTEMS SYDNEY AUSTRALIA

Phone +612-9524 9952

www.seceng.com.au

PLEASE READ FIRST

Do's and Don'ts of installing the SED-902 System

- 1. Always install the supplied SED-902 antennas outside.**
- 2. The antennas must be installed at least 3 metres away from any other antenna or transmitting device.**
- 3. If installing multiple SED-902 systems in one location, call Sec.Eng Systems for assistance on how to best configure.**
- 4. The SED-902 system supplied is ready to use out of the box - No programming required.**

Failing to follow the installation instruction may void the warranty of the system.

SYSTEM OVERVIEW

The SED-902 Remote-Master system is designed to allow for a card reader(s) to operate wirelessly with an access control system between two fixed locations. The Wiegand or Gallagher (Cardax) card data is sent via a 900MHz encrypted radio link, between the fixed locations of the Remote and Master base units.

The system has an operational line of sight range of up to 500m, which can be further extended with the optional high gain antennas. Range is subject to RF conditions at location.

The SED-902 Remote-Master system also provides 4 x normally open inputs at the Master which are crossed over to 4 x relay outputs on the Remote, and vice versa. This can be used for an input to follow output set up, as well as general I/O control.

The system can support up to 10 Remote units with the use of the SED-902 Expander. (An additional Expander is required for each extra Remote unit added to the system).

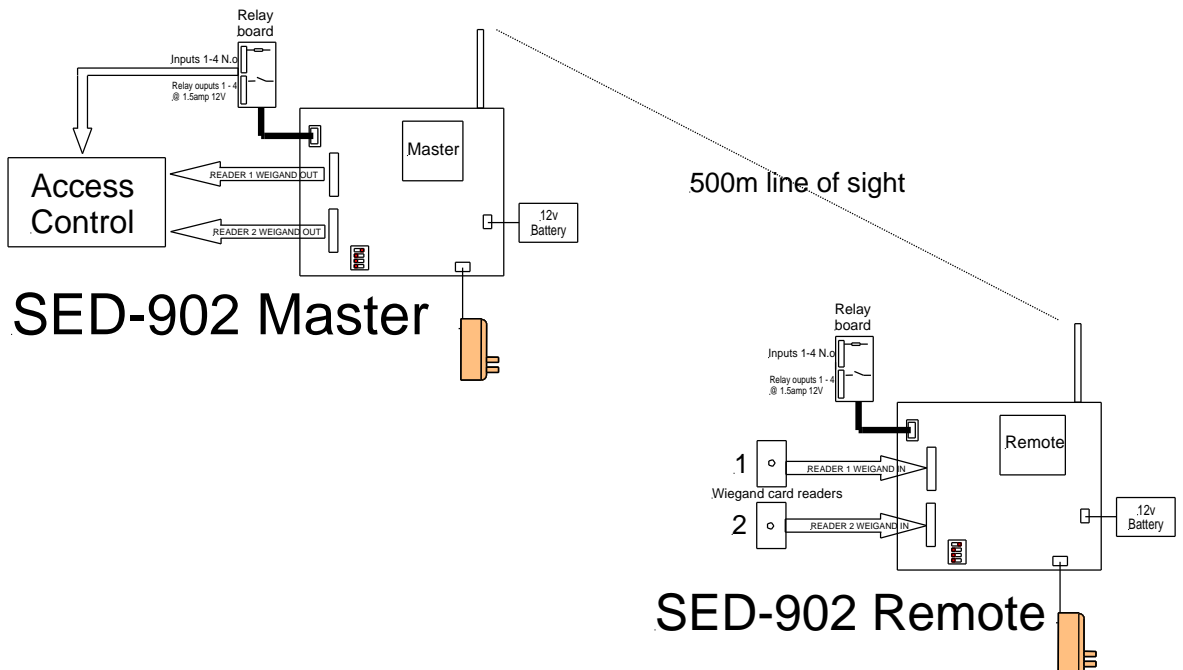

QUICK INSTALLATION GUIDE

The SED-902 Remote and Master/Expander have been factory programmed and tested.

Installation is a simple **PLUG & PLAY** - there is no programming required.

1. Wire the Reader ports on the Master to the access control system (use the **OUTPUT** legend on the Master board, see page 8-11).
2. Wire the Reader ports on the Remote to the card reader (use the **READER** legend on the Remote board, see page 8-11).
3. Fit the supplied antennas and connect power (16V AC plug pack supplied or external 12V DC source, see page 5) to both the SED-902 Remote and Master units.
4. Check that a link has been established between the Remote and Master:
Link LED on both the Remote and Master should be on.
Signal level LED on Remote and Master should be above 4 bars .
5. Test with a working access card.

See the following pages for detailed installation instructions

REMOTE & MASTER BOARD LAYOUT & CONNECTIONS

The SED-902 Remote–Master system utilise the same board for the Remote and Master units. The boards are allocated as Remote or Master by setting the MODE dip switch on the board. See page 6 for details

BOARD TERMINAL CONNECTIONS

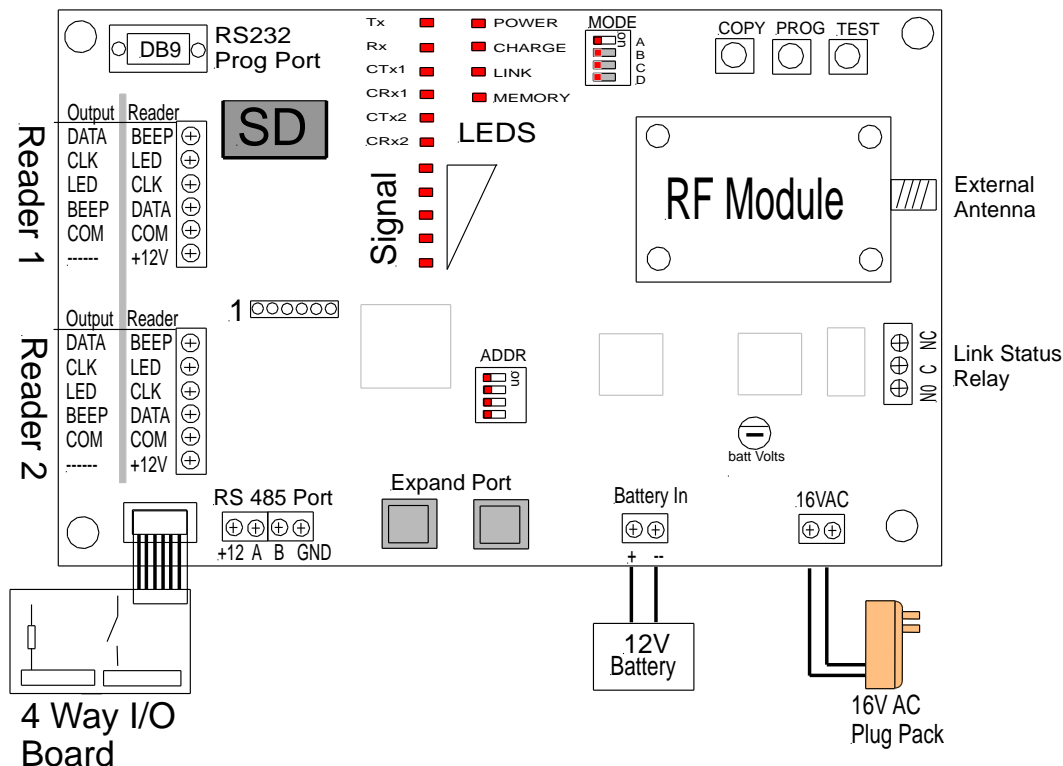

AC Power in

16VAC = 16V AC 1.5Amps

Battery in

+BAT- = 12V 7AH gel cell / SLA backup battery

RS485 Port

+12 = 12V output for devices or 12V DC power input.

A = data (not used)

B = data (not used)

COM = Common

Link Status Relay

Used for RF signal status. The relay is active when there is an RF link between the Master and Remote units.

RS323 DB9 Port

Programming port for PC configuration (See page 13)

EXP PORT (RJ12)

Used to link the SED-902 Expander units (See page 12)

Relay Board Operation

The Relay System is simple – inputs on the Relay board follow outputs

Example: If you trigger Input 1 on either Relay board, it will then trigger Relay 1 on the opposite board

LED INDICATORS

POWER= Power on

CHARGE = Indicates battery charging (if fitted)

LINK = Indicates if RF link is established

MEMORY = Indicated SD card fitted (not used)

TX = Packet being transmitted

RX = Packets being received

CTX1= Reader 1 (IN) transmitting data

CRX1= Reader 1 (IN) receiving data

CTX2= Reader 2 (OUT) transmitting data

CRX2= Reader 2 (OUT) receiving data

Signal LEDs = 1-5 signal level (low to high)

TX	■	■	POWER
RX	■	■	CHARGING
CTX1	■	■	LINK
CRX1	■	■	MEMORY
CTX2	■		
CRX2	■		

LEDS

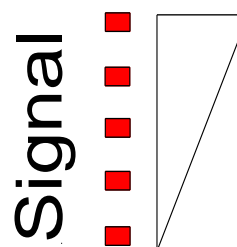

MODE DIP SWITCH (TOP OF BOARD)

Switch 1: ON = Master OFF = Remote

Switch 2: ON = Cardax systems OFF = Wiegand systems

Switch 3: Not used

Switch 4: ON = Program mode via serial port (115.2k 8-N-1)

 OFF = GPS port data mode where fitted output (9600 8-N-1)

ADDRESS DIP SWITCH (MIDDLE OF BOARD)

Used for Expanders addressing, see page 12.

PUSH BUTTON SWITCHES

COPY = Used for enrolling the system (see page 16)

PROG = Used to enroll, as well as change the radio channel (page 17)

TEST = Used to test the radio linked

ANTENNA INSTALLATION

It is recommended that the antennas of the Remote and Master are mounted on the outside of the building and in clear line of sight of each other. The antennas should be mounted as high as possible and free of any obstruction. Doing this will ensure best possible operational range. The system is supplied with a mounting bracket and a 5m antenna extension lead.

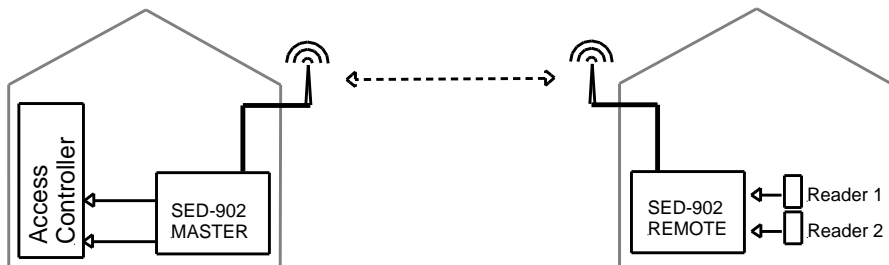

EXTERNAL DC POWER SUPPLY - 12V DC

The SED-902 Master and Remote units can be powered from a 12V DC external source.

Please note: once the board is powered this way, the battery backup charging will be no longer operate.

- Connect a filtered 12V DC source to the power rail on the RS485 port.
- Do not fit the backup battery and AC to the standard inputs.

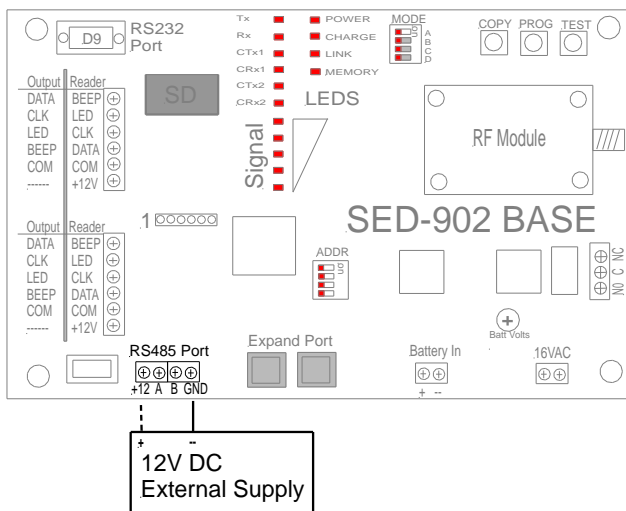

EXTERNAL DC POWER SUPPLY - 24V DC

The SED-902 Master and Remote units can also be powered from a 24V DC external source. The filtered 24V DC supply is connected to the 16V AC terminal.

Please note: Battery back up charging will still operate when the system is powered this way.

WIEGAND SYSTEM SETUP

NOTE: The SED-902 board has dual markings for Master and Remote systems applications. Use the **OUTPUT** markings when connecting to the access controller (Master setup), and **READER** markings for connection to the card readers (Remote setup).

MASTER - ACCESS CONTROLLER CONECTION

MODE DIP SWITCH (top of board):

- 1(A) = On (Set the device as a Master)
- 2(B) = Off (Set the system to Wiegand protocol)
- 3(C) = Off (Not used)
- 4(D) = On (Enable programming via Serial 8n115k port)

SED-902 Output Connections to access control system

DATA -----	To Wiegand controller DATA / D0 (GREEN)
CLK -----	To Wiegand controller CLOCK / D1 (WHITE)
LED -----	To Wiegand controller LED (BROWN/ORANGE)
BEEP -----	To Wiegand controller BUZZER (YELLOW)
COM -----	To Wiegand controller GND / COMMON (BLACK)
+12V	Do not connect

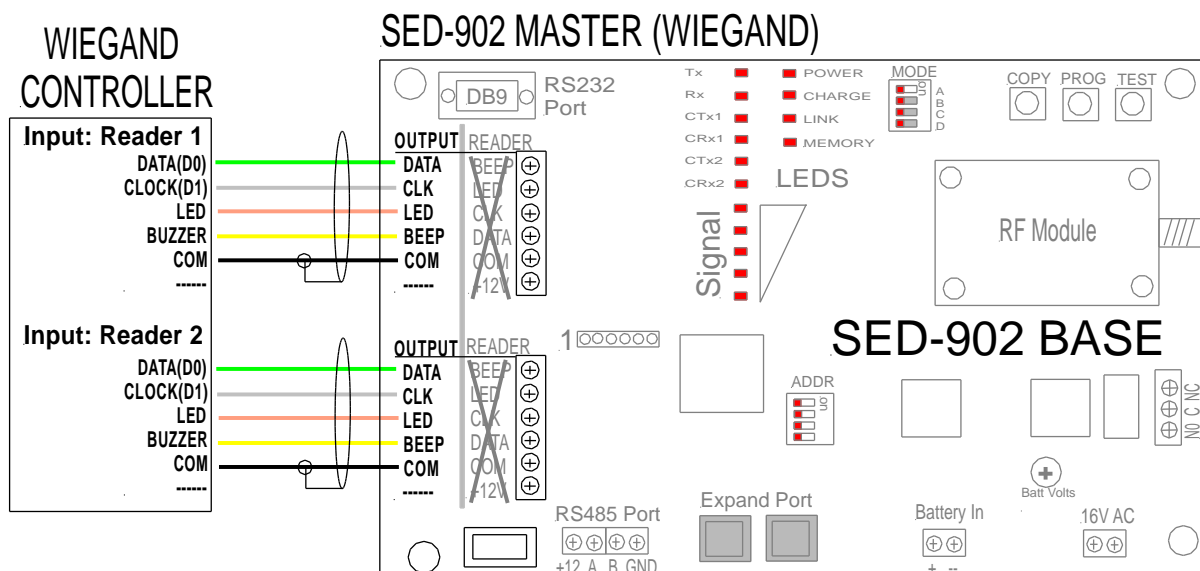

IMPORTANT: If using the SED-902 system on a Gallagher controller with a Wiegand reader adaptor, or a Wiegand system which does not use the standard logic levels of 0-5V, then 2.2kΩ pull up resistors must be fitted on the Master/Expander between the Clock and 12V terminals, as well as Data and 12V terminals.

REMOTE - CARD READER CONNECTION

MODE DIP SWITCH (top of board):

- 1(A) = Off (Set the device as a Remote)
- 2(B) = Off (Set the system to Wiegand protocol)
- 3(C) = Off (Not used)
- 4(D) = On (Enable programming via Serial 8n115k port)

SED-902 Output Connections to access control system

- BEEP ----- To Wiegand card reader BUZZER (YELLOW)
- LED----- To Wiegand card reader LED (BROWN/ORANGE)
- CLK ----- To Wiegand card reader CLOCK / D1 (WHITE)
- DATA ----- To Wiegand card reader DATA / D0 (GREEN)
- COM ----- To Wiegand card reader GND / COMMON (BLACK)
- +12V ----- To Wiegand card reader +12V (RED)

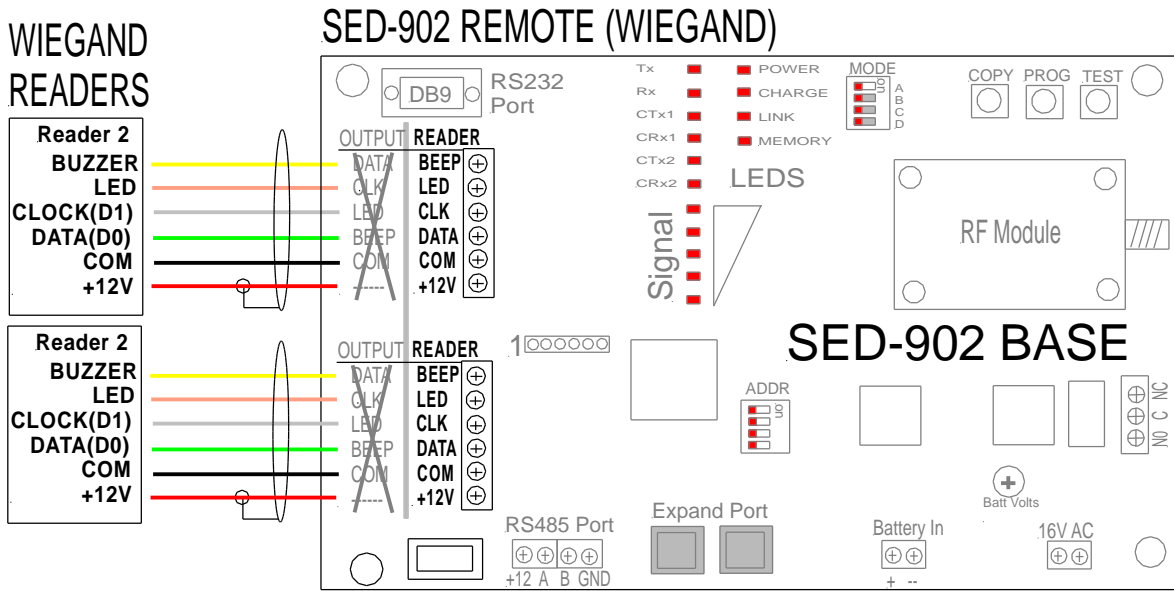

IMPORTANT: If using the SED-902 system on a Gallagher controller with a Wiegand reader adaptor, or a Wiegand system which does not use the standard logic levels of 0-5V, then 2.2kΩ pull up resistors must be fitted on the Master/Expander between the Clock and 12V terminals, as well as Data and 12V terminals.

GALLAGHER (CARDAX) SYSTEM SETUP

NOTE: The SED-902 board has dual markings for Master and Remote systems applications. Use the **OUTPUT** markings when connecting to the access control systems (Master setup), and **READER** markings when connecting to the card readers (Remote setup).

IMPORTANT: The SED-902 only support the Gallagher CARDAX IV interface. HBUS is not supported.

MASTER - ACCESS CONTROLLER CONECTIONS

MODE DIP SWITCH (top of board):

- 1(A) = On (Set the device as a Master)
- 2(B) = On (Set the system to Gallagher CARAX IV protocol)
- 3(C) = Off (Not used)
- 4(D) = On (Enable programming via Serial 8n115k port)

SED-902 Output Connections to access control system

DATA -----	To Gallager controller DATA 0 (WHITE)
CLK	Not used
LED	Not used
BEEP -----	To Gallager controller OUT 1 (BLUE)
COM -----	To Gallager controller GND / COMMON (BLACK)
+12V	Do not connect

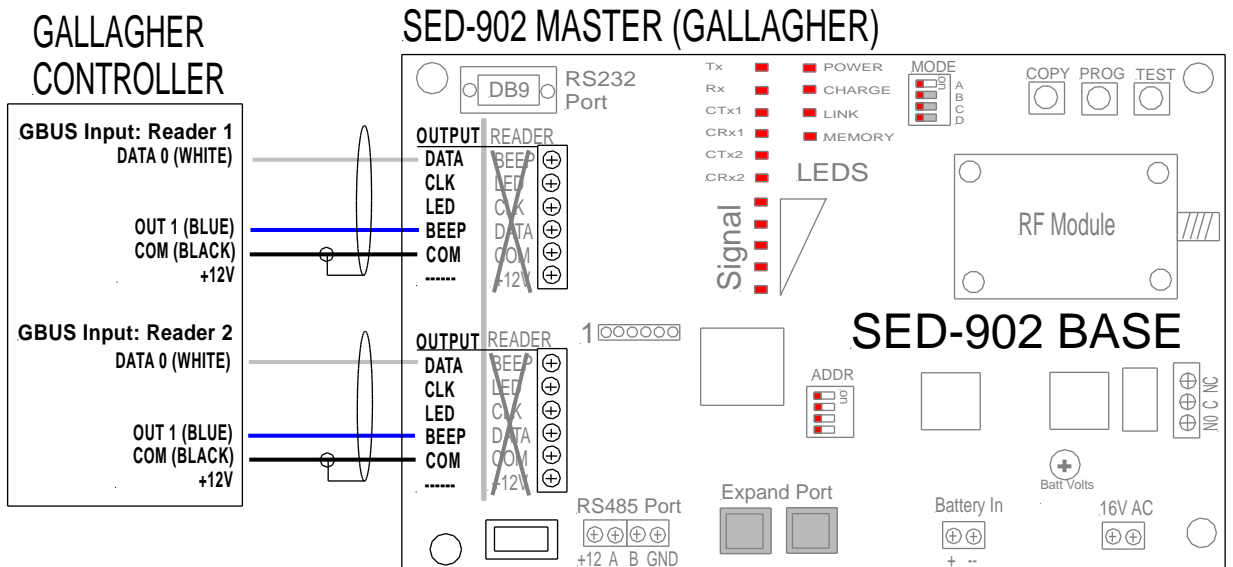

REMOTE - CARD READER CONNECTION

MODE DIP SWITCH (top of board):

- 1(A) = Off (Set the device as a Remote)
- 2(B) = On (Set the system to Gallagher protocol)
- 3(C) = Off (Not used)
- 4(D) = On (Enable programming via Serial 8n115k port)

SED-902 Output Connections to access control system

- BEEP ----- To Gallagher card reader TX (BLUE)
- LED----- Not used
- CLK ----- Not used
- DATA ----- To Gallagher card reader RX (WHITE)
- COM ----- To Gallagher card reader GND / COMMON (BLACK)
- +12V ----- To Gallagher card reader +12V (RED)

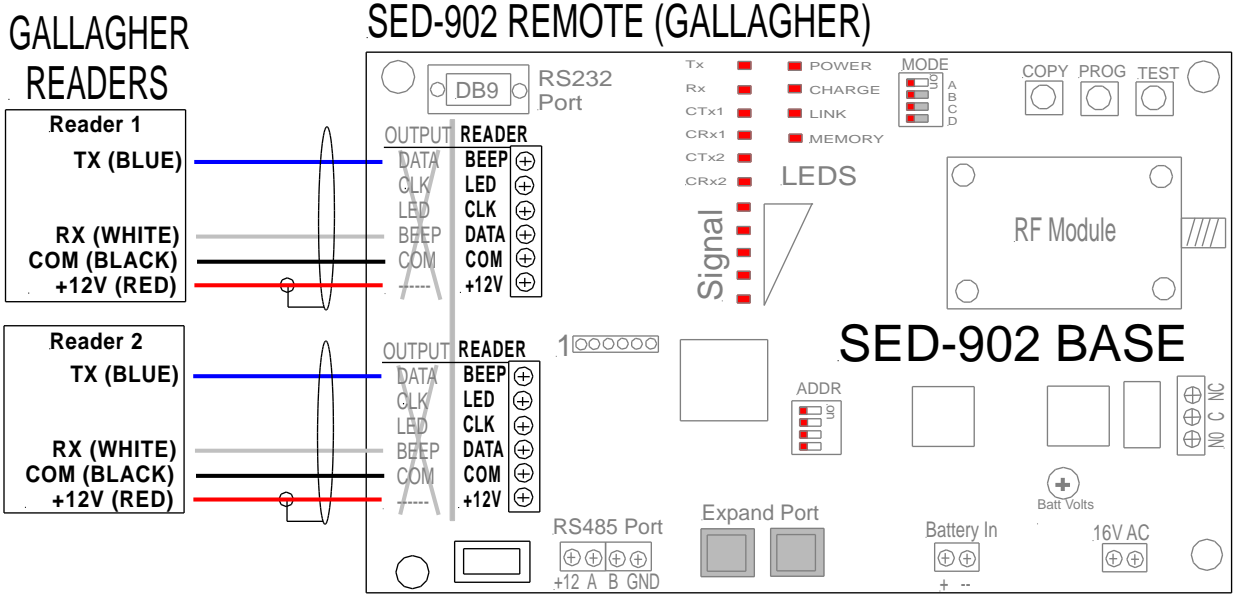

EXPANDER SETUP

The SED-902 Expander allow for additional Remote units to be added to the system and operate on the same radio link as the Master. A Master/Remote unit can support up to 10 Expanders.

Expander are used to allow for multiple Remote units to be added or for additional readers to be added to a Remote unit.

To set up an Expander, follow the steps below:

1. Power down the SED-902 system down while installing the Expander
2. On the Expander **Mode DIP switch**,
 Switch1: ON = Master Expander OFF = Remote Expander
 Switch 2: ON = Cardax systems OFF = Wiegand systems
1. Set the **Address DIP switch** according to the number of Expanders connected off the Master unit. See table below.
2. The Expander gets both power and communications through the RJ12 cable. Only use the cable supplied by Sec.Eng System.
3. If Remote unit isn't already linked to the Expander, It can be re-enrolled by following the instructions on page 16.

NOTE: When any of the DIP switches are changed the entire SED-902 system must be power cycled for it to take effect.

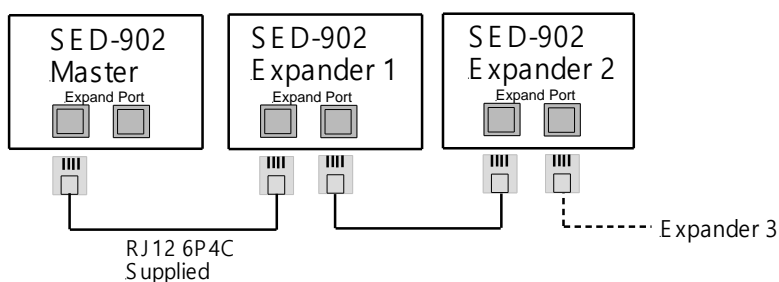

Expander dip switch Address settings									
ADDR switch	1	2	3	4		1	2	3	4
Expander 1	ON				Expander 9	ON			ON
Expander 2		ON			Expander 10		ON		ON
Expander 3	ON	ON			Expander 11	ON	ON		ON
Expander 4			ON		Expander 12			ON	ON
Expander 5	ON		ON		Expander 13	ON		ON	ON
Expander 6		ON	ON		Expander 14		ON	ON	ON
Expander 7	ON	ON	ON		Expander 15	ON	ON	ON	ON
Expander 8				ON					

4-WAY INPUT/OUTPUT

The SED-902 Remote-Master system includes a 4 WAY Input and Output expansion board which

4 x normally open inputs at the Master which are crossed over to 4 x relay outputs on the Remote, and vice versa. This can be used for an input to follow output set up, as well as general I/O control.

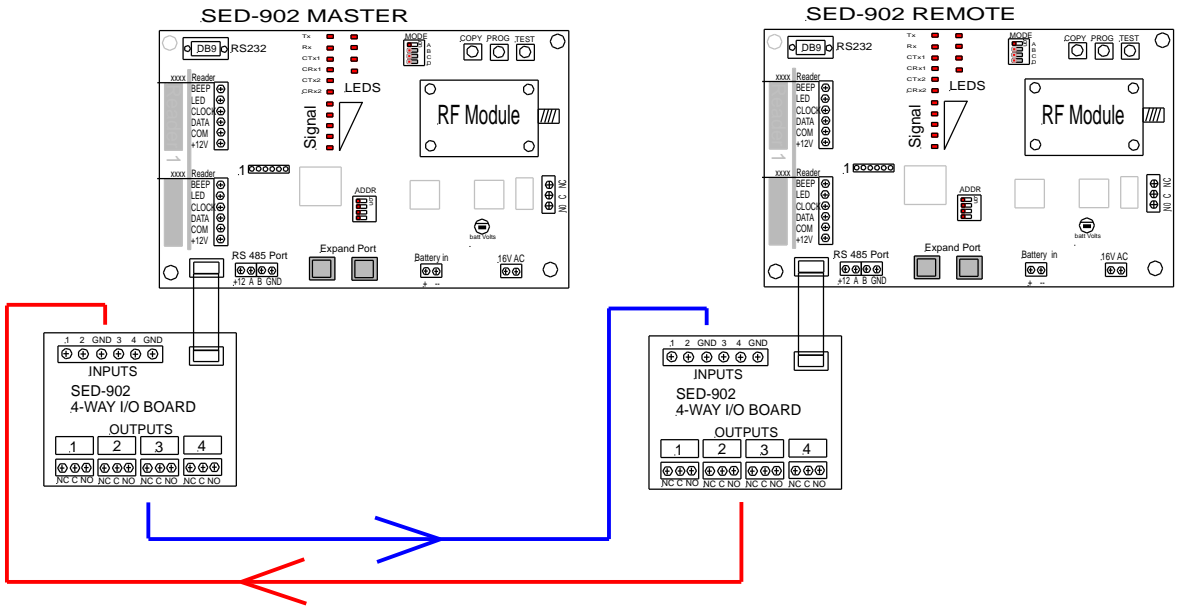

PC PROGRAMMING

NOTE : This is only required if a change to the default setting are needed.

CONNECTING TO THE SED-902 SYSTEM

The SED-902 system can be configured via the DB9 serial port on the Master/Expander board.

To do so follow the steps below:

1. Turn MODE dip switch 4 on the Master/Remote/Expander board to enable the serial port.
2. Power cycle the Master/Remote/Expander for the dip switch change to take effect.
3. Connect to a PC to the serial port. (a USB to Serial adapter may be needed if using a laptop).
4. Use a terminal commands software, such as HyperTerminal or Ucon to communicate with the SED-902 system.
Use the following connection settings:
Data=8, Parity=None, Stop Bit=1, Flow=RTS/CTS, Baud Rate=115200.
5. When connected to the SED-902 system hit the Enter key. A password request should appear. The login password is:
zxcvbnm
6. Enter **?P** to view the full list of readable and programmable parameters.
7. To change any of the programmable parameters, type the parameter name followed by = and then the value you wish to change it to.
Example: to change the System ID Parameter to 4312, type:
System ID=4312
and then hit enter. The change should display on screen.

PROGRAMMABLE PARAMETERS

SYSTEM ID = *** [0 to 30000] Default =1138859959 or set by Sec.Eng Systems**

This sets the Radio ID tag. It must be changed when more than one Remote-Master pair operating in the same area.

To change type **system id=xxxxx (up to 10 digits)** and then hit enter.

You must power cycle both the Remote and the Master for this change to take effect.

You may need to re-enroll the two units - see page 16.

Every SED-902 Master & Remote unit is supplied by Sec.Eng Systems with a unique system ID number already configured, which is also marked on the board (SID: XXXXX).

Note: The System ID can also be set by using the Address Dip switch on the Master.

ADDR MODE = * [0 to 1] Not used, DO NOT CHANGE

CHANNEL = * [0 to 10] **Default = 4**

This sets the operation radio channel frequency. You would only change this if you have more than one Remote and Master operating in the same area.

Channel options:

0 = 916MHz	6 = 922MHz
1 = 917MHz	7 = 923MHz
2 = 918MHz	8 = 924MHz
3 = 919MHz	9 = 925MHz
4 = 920MHz	10 = 926MHz
5 = 921MHz	11 = 927MHz (RESERVED)

To change type **channel=0-10**.

When this is changed, you must power cycle both the Remote and Master. Make sure to change the channel on both the Master and Remote units to the same channel.

Note: The Channel can also be set by using the push buttons on the Master and Remote boards. See page 20.

SCAN START = * [0 to 10] sets the scan channel range, DO NOT CHANGE

SCAN END = * [0 to 10] Not used, DO NOT CHANGE

PROTOCOL = * [Cardax or Wiegand or Wiegand Direct] **Default = Wiegand**

This set the protocol for the card data ports.

Cardax = Supports the Gallagher / CARDAX IV protocol.

Wiegand = Supports the standard Wiegand protocol with standard card reader beep response (Double beep = Granted, Five beeps = Denied).

Wiegand direct = Supports the Wiegand protocol with the card reader beeps following the output of the access control system.

- To configure for Cardax, set then MODE dip switch B to the ON position and power cycle



- To configure for Wiegand, set then MODE dip switch B to the OFF position and power cycle



- To configure for Wiegand Direct, set then MODE dip switch B to the OFF position, power cycle and enter the command **Wiegand direct 1** (enable Wiegand direct).

Note: to disable Wiegand direct and enter **Wiegand direct 0**.

FAULT FINDING GUIDE

COMMUNICATION ISSUES

No data received at access control system

- Test the access control system by wiring a card reader directly.
- Check the wiring between access system and Master/Expander (must be wired to the correct legend – OUTPUT).

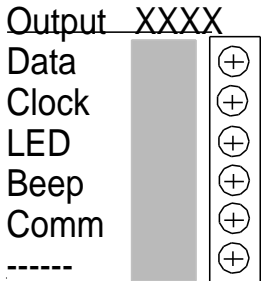

- Check the wiring between card readers and Remote/Expander (must be wired to the correct legend – READER).

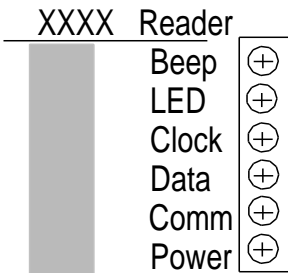

- Check the Com terminal on Master Reader1/Reader2 is wired to access system.
- Check D1(Clock) and D0(Data) are wired in the correct orientation.
- For a Wiegand system, check that it operate on the standard 0-5V logic (measure the voltage between Data (D0) and common).

If it lower than 5V then pull up resistors will need to be fitted on the Master/Expander Output terminals. Fit a 2.2kΩ resistor between the CLK and 12V terminals and another 2.2kΩ resistor between DATA and 12V terminals.

Data went through but no LED or Beeps by the reader

- Check wiring for Buzzer/Beep and LED outputs between the Master/Expander and access system.

DEFAULTING MASTER / REMOTE / EXPANDER

The default procedure is the same for the Master, Remote and Expander units. By defaulting the board, all setting will be reset and including the pairing information (Re-Enrollment of units will be required).

To default:

1. Press and hold the COPY, PROG and TEST buttons for 3 seconds.
2. Once the unit resets (LEDs will cycle through), release the buttons and it will now be defaulted.

Note: Do not default two Master units that are within RF range as the defaulted System ID will cause interference between the two transmitting units. See page 13 to change the System ID.

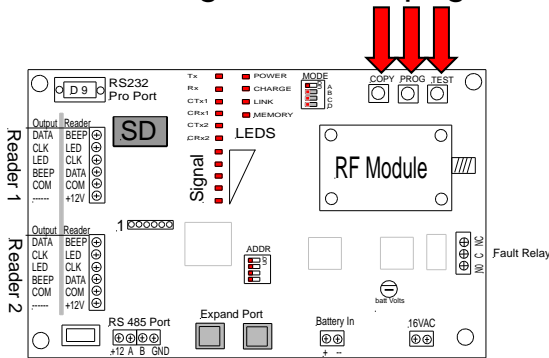

RE-ENROLLING MASTER / REMOTE / EXPANDER

1. Press and hold the **PROG** and **COPY** buttons on the Master/ Expander unit. Once the signal LED starts scanning up and down, the buttons can be released - the unit will now be in learn mode

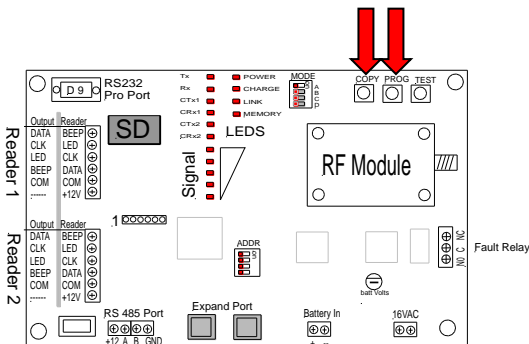

2. Repeat the same process on the Remote/Expander unit.
3. The two units will then auto enroll within 30 seconds
4. Check the LINK and signal level LEDs are active on both units.

Note: If the Master and Remote unit do not establish a link for some reason they will both timeout of pairing mode after 2 minutes. You can also stop the pair routine at anytime by holding the TEST button

CHANGING THE RADIO CHANNEL

When there are multiple SED-902 systems operating within range of each other the radio channel used by each system can be changed to prevent an interference between them.

This can be done two ways:

- Connecting the Master/Remote to a PC via the serial port and setting this (see pages 13-14)
- By using the buttons and LEDs on the Master/Remote to set:
 1. Press and hold the PROG buttons until the Memory LED starts flashing, inducting you in Channel programming mode.

While in this mode the LEDs on the board will indicate what channel is currently selected and the TEST button will cycle between the channels.

Ch 0 = TX	■	■	POWER
Ch 1 = RX	■	■	CHARGING
Ch 2 = CTX1	■	■	LINK
Ch 3 = CRX1	■	■	MEMORY
Ch 4 = CTX2	■		
Ch 5 = CRX2	■		
Ch 6 =	■		
Ch 7 =	■		
Ch 8 =	■		
Ch 9 =	■		
Ch 10 =	■		

LEDS

Signal

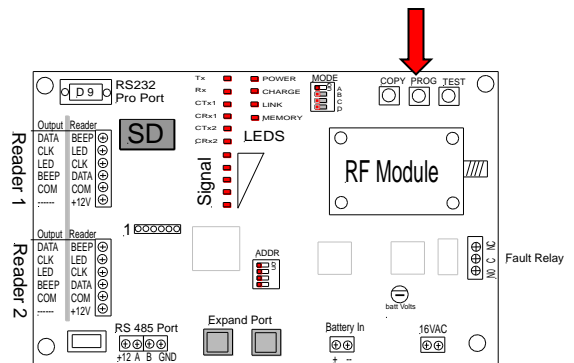

CHANNEL	FREQUENCY	CHANNEL	FREQUENCY
Ch 0	916MHz	Ch 6	922MHz
Ch 1	917MHz	Ch 7	923MHz
Ch 2	918MHz	Ch 8	924MHz
Ch 3	919MHz	Ch 9	925MHz
Ch 4	920MHz	Ch 10	926MHz
Ch 5	921MHz	Ch 11	927MHz (RESERVED)

2. Press the TEST button until the LED representing the desired channel is illuminated.
3. Press and hold the PROG button until the Memory LED goes off. This will then save the new channel selection.

Note: Once the channel has been changed the Master, the process my be repeated on the Remote unit.

TECHNICAL SPECIFICATIONS

RADIO SPECIFICATIONS	
Type	Semtech LoRa
Frequency Operational	916MHz - 927MHz
Transmit Power	100mW
Security Encryption	By Request
Operational Range	500 metres (Line of sight)
ACCESS PROTOCOL SUPPORTED	
Wiegand	240bit (up to)
Gallagher/Cardax	CARDAX IV (HBUS not supported)
SED-902 MASTER	
Power Pack Input	230V-240VAC
Power Pack Output	16V AC 1.5A
External Power Supply	12V or 24V DC 2.5A
Backup Battery	12V 7Ahr gel cell (Not included)
Antenna Connection	SMA Female
Antenna Type	External 3dB Omni (High Gain Optional)
Dimensions	235 x 250 x 80mm(Metal Cabinet)
SED-902 REMOTE	
Power Pack Input	230V-240VAC
Power Pack Output	16V AC 1.5A
External Power Supply	12V or 24V DC 2.5A
Backup Battery	12V 7Ahr gel cell (Not included)
Antenna Connection	SMA Female
Antenna Type	External 3dB Omni (High Gain Optional)
Dimensions	235 x 250 x 80mm(Metal Cabinet)
SED-902 EXPANDER	
Power Input	Supplied by Master via RS485 link
Antenna connection	Not applicable
Dimensions	235 x 250 x 80mm (Metal Cabinet)
CERTIFICATION	
FCC (FCC Identifier 2ASK9-MX001W4814) MAY 2019 USA	

FCC IDENTIFIER: 2ASK9-MX001W4814
Name of Grantee: Sec-Eng Systems Pty Ltd.
Equipment Class: Digital Transmission System
Notes: Sed Lawra-R1
Modular Type: Single Modular

