



SED-902 Handheld-Master Installation Guide

Wiegand & Gallagher (Cardax) System

April 2022

**WARNING: PLEASE READ THIS GUIDE PRIOR TO ATEMPTING
THE INSTALLATION OF THE SED-902 SYSTEM**

PRODUCT WARRANTY

This product is covered by a 12 month, back to base warranty from date of purchase, and proof of purchase should be supplied. The warranty does not cover damage that has resulted from the improper installation or improper use of this product. The warranty does not cover lightning damage, product misuse, electrical surges or acts of God.

LIMITATION OF LIABILITY

Sec.Eng Systems Pty Ltd does not accept any liability for the loss or damage to property or persons in relation to goods supplied. This disclaimer is only limited to the warranty of the goods supplied and the intended use.

NOTE: THIS MANUAL IS SUBJECT TO COPYRIGHT

SEC-ENG SYSTEMS SYDNEY AUSTRALIA

Phone +612-9524 9952

www.seceng.com.au

PLEASE READ FIRST

Do's and Don'ts of installing the SED-902 System

- 1. Always install the supplied SED-902 antennas outside.**
- 2. The antennas must be installed at least 3 metres away from any other antenna or transmitting device.**
- 3. If installing multiple SED-902 systems in one location, call Sec.Eng Systems for assistance on how to best configure.**
- 4. The SED-902 system supplied is ready to use out of the box - No programming required.**

Failing to follow the installation instruction may void the warranty of the system.

SYSTEM OVERVIEW

The SED-902 Handheld-Master system is designed to allow for a portable card reader to operate wirelessly with an access control system. The Wiegand or Gallagher (Cardax) card data is sent via a 900MHz encrypted radio link between the SED-902 Handheld and Master base unit.

The system has an operational line of sight range of up to 400m, which can be further extended with the optional high gain antennas. Range is subject to RF conditions at location.

The SED-902 Master can provide 2 outputs that are selectable from the Handheld. This allows the presented card to be directed to the Reader 1 (IN) or Reader 2 (OUT) ports on the Master control unit.

The system can support up to 10 Handhelds with the use of the SED-902 Expander units. (An additional Expander is required for each extra Handheld added to the system).

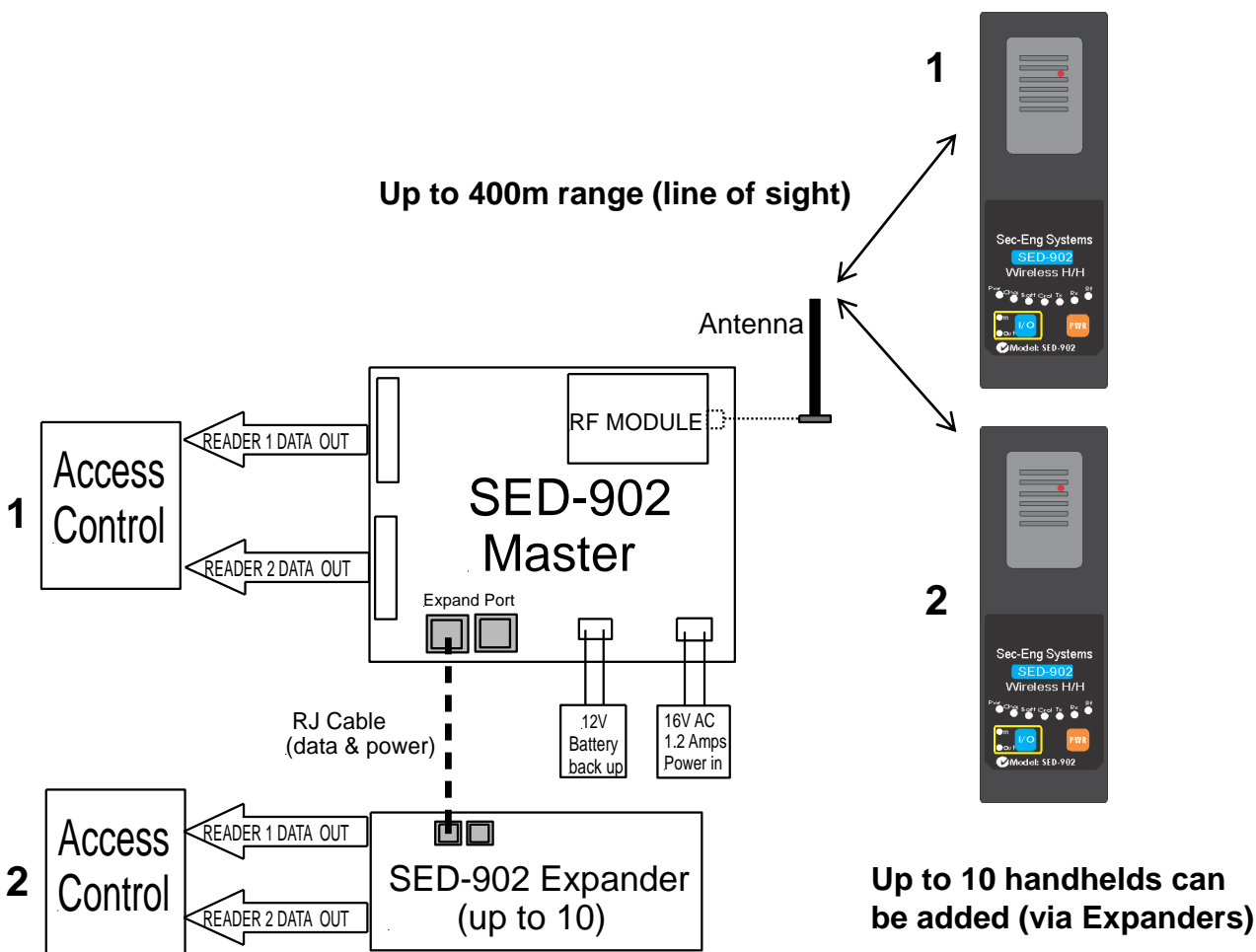

QUICK INSTALLATION GUIDE

The SED-902 Handheld and Master/Expander have been factory programmed and tested.

Installation is a simple **PLUG & PLAY** - there is no programming required.

1. Wire the Reader ports on the Master to the access control system (use the **OUTPUT** legend on the Master board, see page 9-10)
2. Fit the supplied antenna and connect power to the SED-902 Master (16V AC plug pack supplied or external 12V DC source, see page 6).
3. Power up the SED-902 Handheld by pressing and holding the PWR button for 3 seconds.
4. Check that a link has established between the Handheld and Master:
 - Rf** LED on Handheld should be green.
 - Link** LED on Master should be on.
5. Test the card reader with a working access card.

SEE FOLLOWING PAGES FOR DETAILED INSTALLATION INSTRUCTIONS

MASTER BOARD LAYOUT & CONNECTIONS

BOARD TERMINAL CONNECTIONS

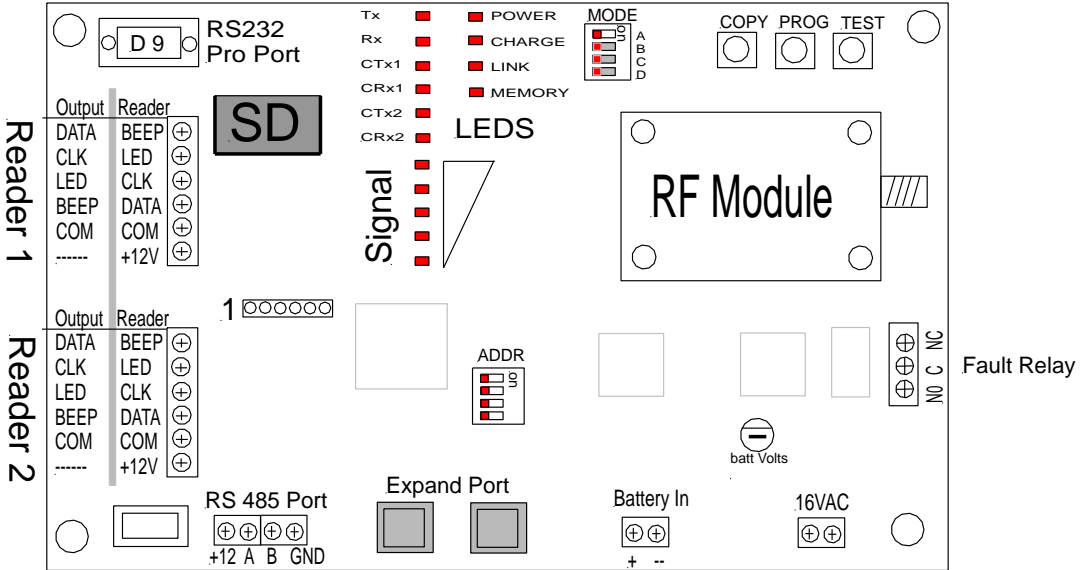

AC Power in

16VAC = 16V AC 1.5Amps

Battery in

+BAT- = 12V 7AH gel cell / SLA backup battery

RS 485 Port

+12 = for input or output devices or 12V DC power input.

A = data (not used)

B = data (not used)

COM = Common

Fault Relay

Used for RF signal status. The relay is active if a Handheld is within RF range and is linked to the Master unit.

DB 9 Serial

for PC configuration (See page 14)

EXP PORT (RJ12)

Used to link the SED-902 Expander units (See page 8)

MASTER LED INDICATORS

POWER= Power on

CHARGE = Indicates battery charging (if fitted)

LINK = Indicates if RF link is established

MEMORY = Indicated SD card fitted (not used)

TX = Packet being transmitted

RX = Packets being received

CTX1= Reader 1 (IN) transmitting data

CRX1= Reader 1 (IN) receiving data

CTX2= Reader 2 (OUT) transmitting data

CRX2= Reader 2 (OUT) receiving data

Signal LEDs = 1-5 signal level (low to high)

TX	■	■	POWER
RX	■	■	CHARGING
CTX1	■	■	LINK
CRX1	■	■	MEMORY
CTX2	■		
CRX2	■		

LEDS

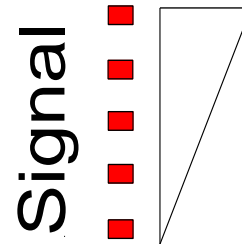

MODE DIP SWITCH (TOP OF BOARD)

Switch 1: ON = Master OFF = Remote

Switch 2: ON = Cardax systems OFF = Wiegand systems

Switch 3: Not used

Switch 4: ON = Program mode via serial port(115.2k 8-N-1)

OFF = GPS port data mode where fitted output (9600 8-N-1)

ADDRESS DIP SWITCH (MIDDLE OF BOARD)

Used for Expanders addressing, see page 8

PUSH BUTTON SWITCHES

COPY = Used to enroll a Handheld (see page 19)

PROG = Used to enroll a Handheld, as well as change the channel (page 20)

TEST = Used to test the linked Handheld

ANTENNA INSTALLATION

It is recommended that the antenna is mounted on the outside of the building and in clear line of sight of the SED-902 Handheld. The antenna should be mounted as high as possible and free of any obstruction. Doing this will ensure best possible operational range. The system is supplied with a mounting bracket and a 5m antenna extension lead.

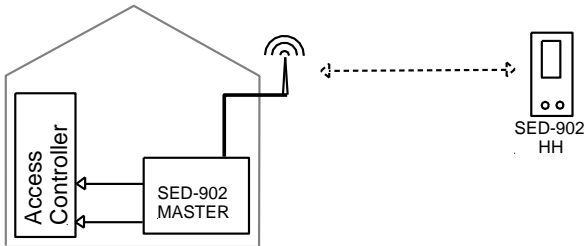

EXTERNAL DC POWER SUPPLY - 12V DC

The SED-902 Master unit can be powered from a 12V DC external source. Please note: once the board is powered this way, the battery backup charging will be no longer operate.

- Connect a filtered 12V DC source to the power rail on the RS485 port.
- Do not fit the backup battery and AC to the standard inputs.

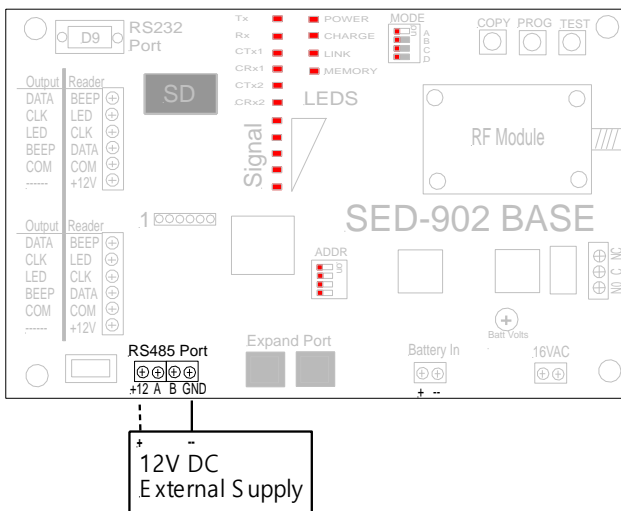

EXTERNAL DC POWER SUPPLY - 24V DC

The SED-902 Master unit can also be powered from a 24V DC external source. The filtered 24V DC supply is connected to the 16V AC terminal. Please note: Battery back up charging will still operate when the system is powered this way.

EXPANDER SET UP

The Expander units allow for additional handhelds to be added to the system and operate on the same radio link as the Master. A Master unit can support up to 10 Expanders.

To set up an Expander, follow the steps below:

1. Power down the SED-902 system down while installing the Expander
2. On the Expander **Mode DIP switch**, ensure Switch1 = ON
Switch 2: ON = Cardax systems OFF = Wiegand systems
1. Set the **Address DIP switch** according to the number of Expanders connected off the Master unit. See table below.
2. The Expander gets both power and communications through the RJ12 cable. Only use the cable supplied by Sec.Eng System.
3. If a Handheld isn't already linked to the Expander, It can be re-enrolled by following the instructions on page 19.

NOTE: When any of the DIP switches are changed the entire SED-902 system must be power cycled for it to take effect.

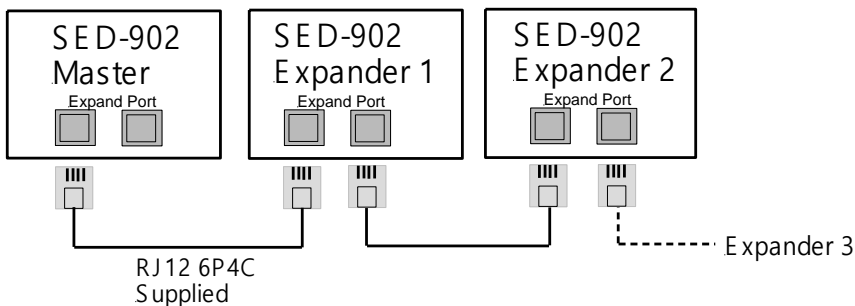

Expander dip switch Address settings									
ADDR switch	1	2	3	4		1	2	3	4
Expander 1	ON				Expander 11	ON	ON		ON
Expander 2		ON			Expander 12			ON	ON
Expander 3	ON	ON			Expander 13	ON		ON	ON
Expander 4			ON		Expander 14		ON	ON	ON
Expander 5	ON		ON		Expander 15	ON	ON	ON	ON
Expander 6		ON	ON						
Expander 7	ON	ON	ON						
Expander 8				ON					
Expander 9	ON			ON					
Expander 10		ON		ON					

MASTER-ACCESS CONTROL CONNECTIONS

Note: The SED-902 Base board has dual markings for Master and Remote systems applications. Use the **OUTPUT** markings for connection to the access control system.

FOR WIEGAND SYSTEMS:

MODE DIP SWITCH (top of board): **Switch 2 =OFF**

SED-902 Output

Connections to access control system

- DATA -----To Wiegand controller DATA / D0 (GREEN)
- CLK -----To Wiegand controller CLOCK / D1 (WHITE)
- LED -----To Wiegand controller LED (BROWN/ORANGE)
- BEEP -----To Wiegand controller BUZZER (YELLOW)
- COM -----To Wiegand controller GND or COMMON (BLACK)
- +12V Do not connect

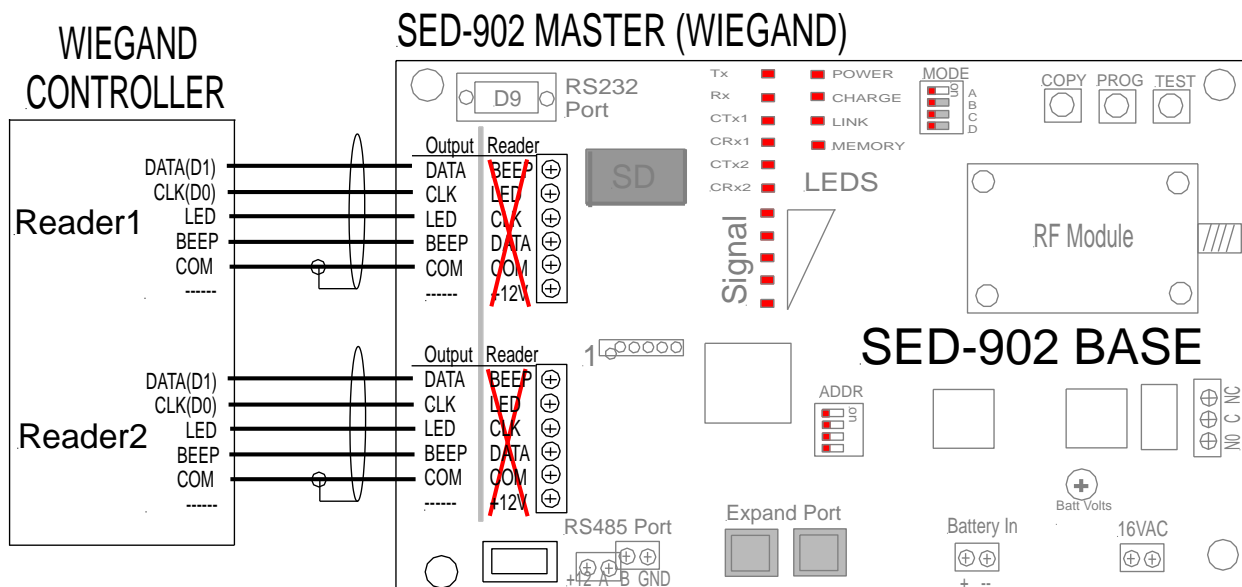

IMPORTANT: If using the SED-902 system is on a Gallagher controller with a Wiegand reader adaptor, or a Wiegand system which does not use the standard logic levels of 0-5V, then 2.2kΩ pull up resistors must be fitted on the Master/Expander between the Clock and 12V terminals, as well as Data and 12V terminals.

FOR GALLAGHER (CARDAX) SYSTEMS:
 MODE DIP SWITCH (top of board): **Switch 2 =ON**

IMPORTANT: The SED-902 Master/Expander must be connected to the G BUS of the Gallagher controller. (H BUS is not supported)

SED-902 Output Connections to access control system

DATA -----To Cardax Controller DATA 0 or 1(WHITE)

CLK -----Not used

LED -----Can be used to trigger internal buzzer on Handheld

BEEP -----To Cardax Controller OUT 1 or 2(BLUE)

COM -----To Cardax controller GND or COMMON (BLACK)

+12V Do not connect

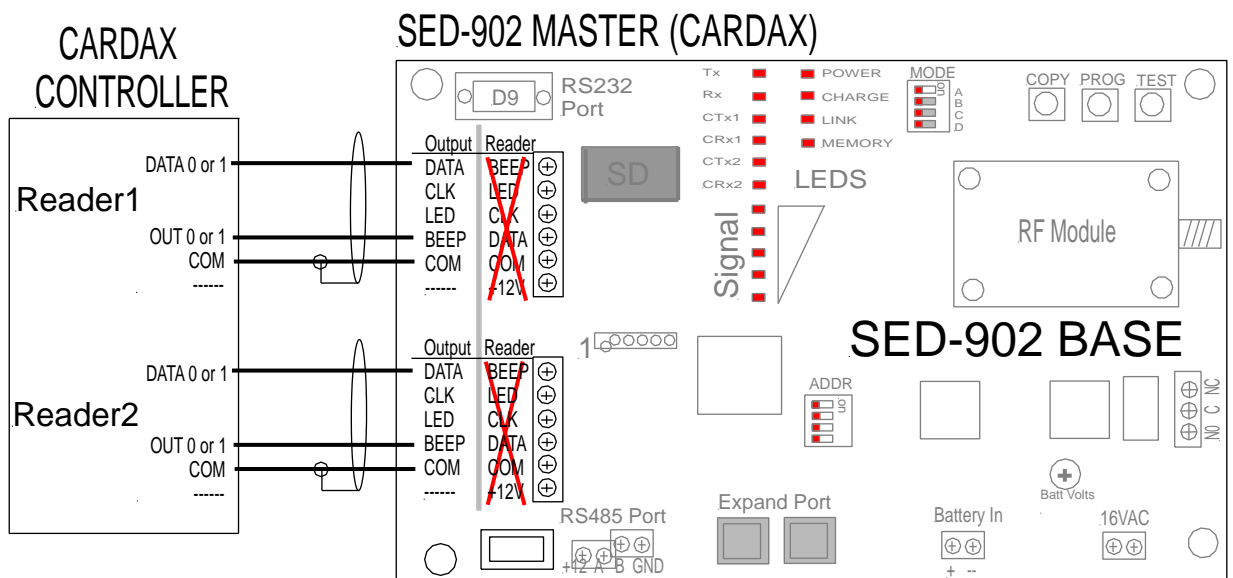

HANDHELD SET UP

HANDHELD OVERVIEW

The SED-902 Handheld features a number of LEDs on the front that provide the user with information on the current status of the system.

This includes the RF LED which indicates the radio link status back to the base Master/Expander.

HANDHELD LEADS

- RF LED** **GREEN (constant)** = Full signal
GREEN (fast flashing) = Medium signal
GREEN (slow flashing) = Poor signal
RED (flashing) = No signal
 OFF= Handheld Radio system is off
- RX LED** **GREEN** = indication that the unit is receiving data
- TX LED** **GREEN** = indication that the unit is transmitting data
- CRD LED** **YELLOW** = indicates when the Handheld is sending card data to Master/Expander
- BATT LED** **when unit is running on battery**
GREEN (flash every 10 seconds) = Battery OK
RED (flashing) = Battery low
- CHG LED** **GREEN (fast flashing)** = Charging
GREEN (flash every 5 seconds) = Battery fully charged
RED (flashing) = Battery fail or removed
- PWR LED** **when charger is connected**
GREEN (constant) = Voltage from charger is OK (24V DC)
GREEN (flashing) = Voltage from charger is low (less than 24V DC)
- In/Out LED** Show the reader port on the Master/Expander currently selected for sending out the card data.



POWERING ON

Press and hold the **PWR** button for 3 seconds until the all the LEDs come on with a continuous beep. Once this has occurred release the button and the Handheld will stay on.

POWERING OFF

Press and hold the **PWR** button for 3 seconds. When the beeper sounds continuously release button and the Handheld will power off.

Note: If the Handheld is not in use, it will automatically power off after 1 hour (default setting).



SELECTING IN/OUT PORT

Press the **I/O** button to toggle between the IN or OUT position. When the IN position is selected the card data will be directed to the Reader1 port on the Master and when OUT is selected it will be directed to the Reader2 port.

Note: Upon powering up the Handheld, the I/O button will be on the port last selected.

LOCKING THE IN/OUT PORT

The I/O button can be locked in a particular position by the user to avoid accidental changes. This can be done in 2 ways:

- Connect to the Master to a PC via the serial port and setting this (see page 14 - 16)
- By pressing PWR and I/O buttons in a set combination:
 1. With the Handheld powered on, press the power buttons 10 times. The I/O LED will start to alternate between the two positions to indicate it is in the setup mode.
 2. Press the I/O button so that the LED is in the desired I/O position. After a few seconds the handheld will timeout from the setup mode and lock the button in the last set position.

Note: To unlock the I/O button (normal operation) do not press the I/O button during step 2 or default the handheld (see page 18)

HANDHELD BATTERY CHARGING

To charge the Handheld connect the supplied 24V DC charger to the barrel plug on the right hand side of the handheld.

Only the Sec-Eng System supplied charger must be used.

To charge a flat handheld battery will take about 3 hours .

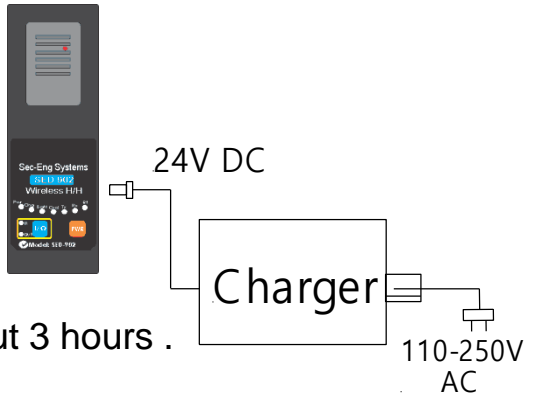

The system feature a charging circuit that will monitor for any issues while attempting to charge, as well as disconnecting the charger when the battery is full.

To best maintain the battery pack life, leave the handheld and connected to the charger when not in use.

Note: When a Handheld is connected to the charger, its radio link will be disabled (Rf LED will be off). This is to allow for another Handheld to be used with the same Master unit while the first one is charging.

To turn on the radio link while charging, press and hold the **PWR** button for 3 seconds. The Rf should return to a green linked status.

Use the **Chg** LED to check the charging stats of the handheld.(see page 11)

HANDHELD CARD READER WIRING DIAGRAM

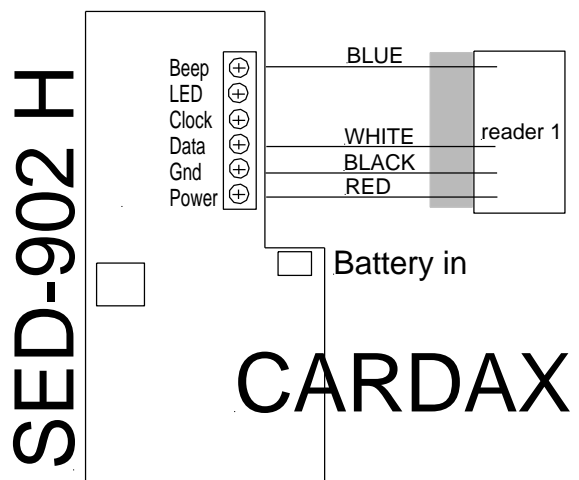
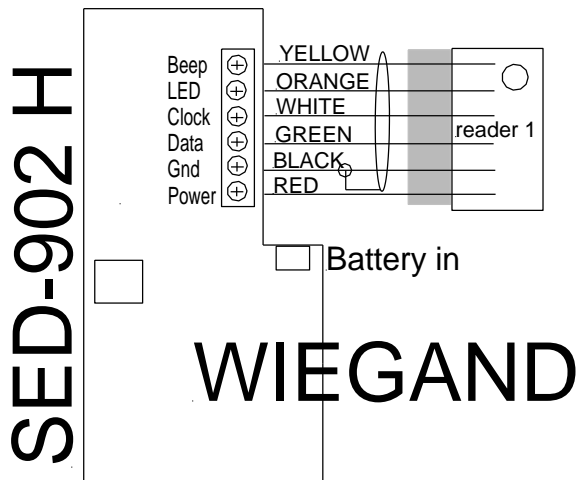

CHANNEL = * [0 to 10] Default = 4

This sets the operation radio channel frequency. You would only change this if you have more than one Handheld and Master operating in the same area.

Channel options:

0 = 916MHz	6 = 922MHz
1 = 917MHz	7 = 923MHz
2 = 918MHz	8 = 924MHz
3 = 919MHz	9 = 925MHz
4 = 920MHz	10 = 926MHz
5 = 921MHz	11 = 927MHz (RESERVED)

To change type **channel=0-10**.

When this is changed, you must power cycle both the Handheld and Master. You will also need to re-enroll the Handheld - see page 19

Note: The Channel can also be set by using the push buttons on the Master board. See page 20.

SCAN START = * [0 to 10] sets the scan channel range, DO NOT CHANGE

SCAN END = * [0 to 10] Not used, DO NOT CHANGE

SLEEP TIME = * [0 to 600] Default =0 seconds**

This allows the Handheld to conserve power by going into sleep mode after a period of time in seconds. This would be used in conjunction with the move wake feature.

To change type **sleep time=1-9**

MOVE WAKE = * [0 to 9] Default =0

This feature will reset the sleep timer when movement of the handheld is detected in any direction. 1 being least sensitive and 9 being the most sensitive. We suggest setting is 5.

To change type **move wake=1-9**

OFF TIME = ** [0 to 3600] Default = 3600 seconds (1hr)**

This sets the Handheld to power off if it is not in use after a period of time.

To change type **off time=0-3600**

BATTERY = * [0 or 1]

This feature enables battery diagnostic mode which display on screen the battery voltage level and charge status.

To change type

battery=0 for diagnostics off

battery=1 for diagnostics on

IN/OUT mode = * [0 or 1 or 2] Default =0

This feature is used to lock the in/out button on the hand held some clients require a handheld to be dedicated to in or out

To do this type

In Out mode=0 for normal button operation

In Out mode=1 for locked on IN

In Out mode=2 for locked on OUT

LED MODE = * [0 or 1] Default =0

This allows for the output of the LED terminal on the Handheld to be inverted as some card readers only having one LED mode.

To change type **led mode=1 or 0**

PROTOCOL = * [Cardax or Wiegand or Wiegand Direct] Default = Wiegand

This set the protocol for the card data ports.

Cardax = Supports the Gallagher / Cardax GBUS protocol.

Wiegand = Supports the standard Wiegand protocol with standard card reader beep response (Double beep = Granted, Five beeps = Denied).

Wiegand direct = Supports the Wiegand protocol with the card reader beeps following the output of the access control system.

- To configure for Cardax, set then MODE dip switch B to the ON position and power cycle



- To configure for Wiegand, set then MODE dip switch B to the OFF position and power cycle



- To configure for Wiegand Direct, set then MODE dip switch B to the OFF position, power cycle and enter the command **Wiegand direct 1** (enable Wiegand direct).

Note: to disable Wiegand direct and enter **Wiegand direct 0**.

EXTERNAL INPUT/OUTPUT CONTROL (OPTIONAL)

HANDHELD OUTPUT (External LED/Buzzer)

The handheld features a 16V output which can be used to drive an external LED and buzzer. The output is controlled from an I/O expansion board which is connected to the Master unit (Optional, PN:SED-902 I/O)

Shorting **Input 1** to **GND** on the I/O board will trigger 16V output on the handheld.

NOTE: Input 1 must be pulled to ground for a minimum of 2 seconds.

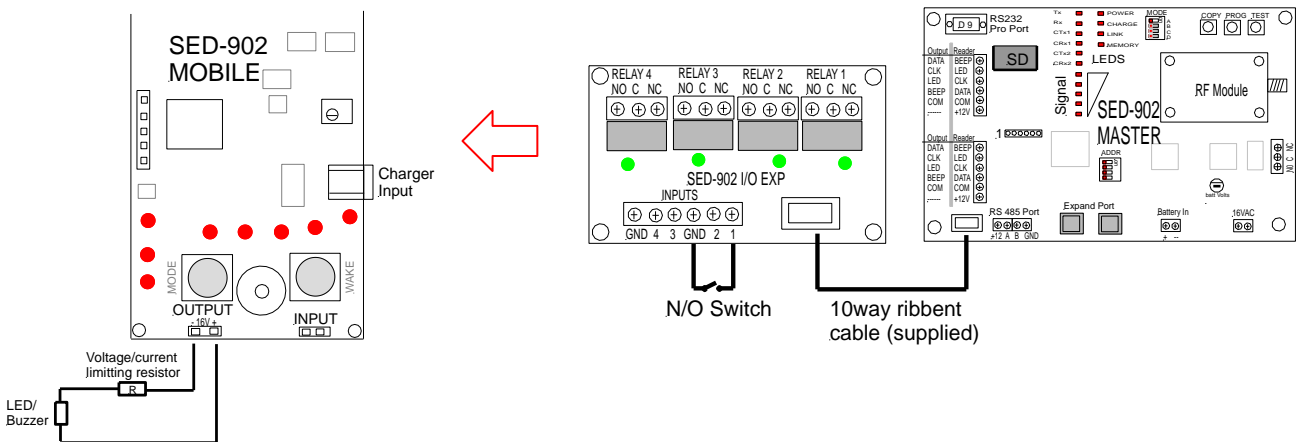

HANDHELD INPUT (External Button)

The handheld also features an input which can be used to control a dry contact relay output on the I/O board connected to the Master unit.

Shorting the input on the handheld will activate **Relay 1** on the I/O board.

NOTE: The Input on the handheld must be shorted for a minimum of 2 seconds.

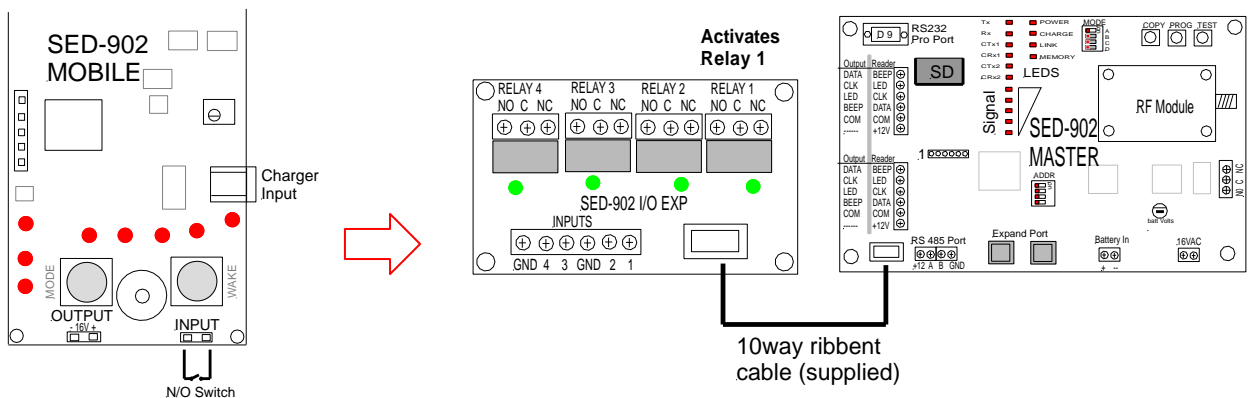

FAULT FINDING GUIDE

COMMUNICATION ISSUES

No data received at access control system

- Test the access control system by wiring a card reader directly.
- Check the wiring between access system and Master/Expander (must be wired to the correct legend – OUTPUT).
- Check the Com terminal on Master Reader1/Reader2 is wired to access system.
- Check D1(Clock) and D0(Data) are wired in the correct orientation.
- Check the handheld is in the correct I/O button position:
IN => Reader 1 OUT => Reader 1
- For a Wiegand system, check that it operate on the standard 0-5V logic (measure the voltage between Data (D0) and common).
If it lower than 5V then pull up resistors will need to be fitted on the Master/Expander Output terminals. Fit a 2.2k Ω resistor between the CLK and 12V terminals and another 2.2k Ω resistor between DATA and 12V terminals.

Data went through but no LED or Beeps by the reader

- Check wiring for Buzzer/Beep and LED outputs between the Master/Expander and access system.

HANDHELD ISSUES

In/Out port not changing when pressing I/O button on Handheld.

- The system has the ability to lock the I/O button in a fixed position. See page 12 on how this is done.

Handheld not holding charge

- The battery pack does have a life of about 1000 full charge cycles. Allow the handheld to charge for 4 hours on the Sec.Eng Systems supplied charger and check the status of the Chg LED. See page 11.

DEFAULTING THE HANDHELD

By defaulting the handheld all settings will be reset and the handheld will need to be re-enrolled with its Master/Expander base unit.

To default:

1. Open the handheld front cover by removing the 4 x Philips screws on the back. This is to allow access to the internal Default button on the PCB.
1. Connect the Handheld to the charger. (Handheld must be on charge to default)
2. Press and hold all 3 buttons on the handheld PCB (I/O, PWR and Default buttons) for 3 seconds.
3. Once the handheld resets, release the buttons and it will now be defaulted.

Note: see page 19 on re-enrolling the handheld with its Master/Expander.

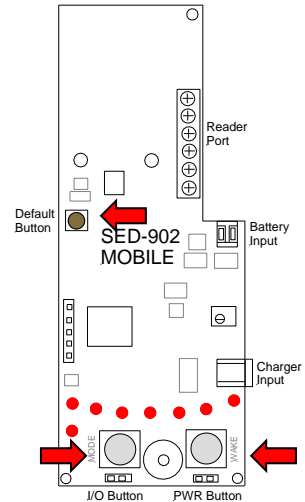

DEFAULTING THE MASTER/EXPANDER

By defaulting the handheld the I/O buttons setting will be reset and the handheld will need to be re-enrolled with its Master/Expander base unit.

To default:

1. Open the handheld front cover by removing the 4 x Philips screws on the back. This is to allow access to the internal Default button on the PCB.
2. Connect the Handheld to the charger. (must be on charge to default)
3. Press and hold all 3 buttons on the handheld PCB (I/O, PWR and Default buttons) for 3 seconds.
4. Once the handheld resets, release the buttons and it will now be defaulted.

Note: Do not default two Master units that are within RF range as the defaulted System ID will cause interference between the two transmitting units. See page 14 to change the System ID.

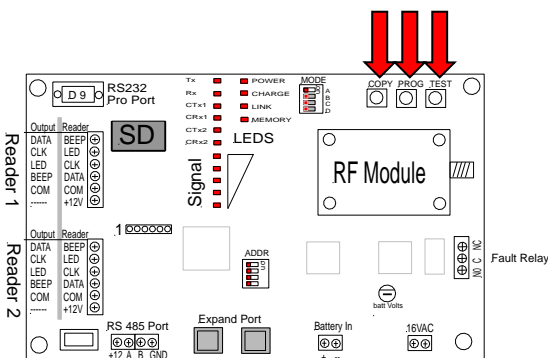

RE-ENROLLING HANDHELD AND MASTER UNIT

1. Press and hold the **PROG** and **COPY** buttons on the Master/ Expander unit. Once the signal LED starts scanning up and down, the buttons can be released - the unit will now be in learn mode.

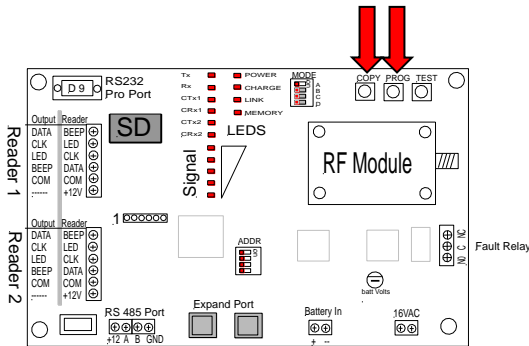

2. With the Handheld powered on, press and hold the IN/OUT button and then press the power button 5 times rapidly. All the LEDs on the front will scan and the unit will auto enroll to the Master/Expander within 30 seconds
3. Power cycle the handheld and test with a card.



Note: If the Master and Handheld do not establish a link for some reason they will both timeout of pairing mode after 2 minutes. You can also stop the pair routine at anytime by holding the TEST button for 5 seconds.

TESTING

1. Ensure the SED-902 Master/Expander is wired into the access control system, and powered up with the Link LED on.
2. Ensure the SED-902 Handheld is powered on and the RF LED is green.
3. Present a valid card to the reader on the Handheld. The reader will beep and transmit card data across to the Master/Expander, which will then present this data to the access control system. LED and buzzer information will be send back to the Handheld just like a wired reader.

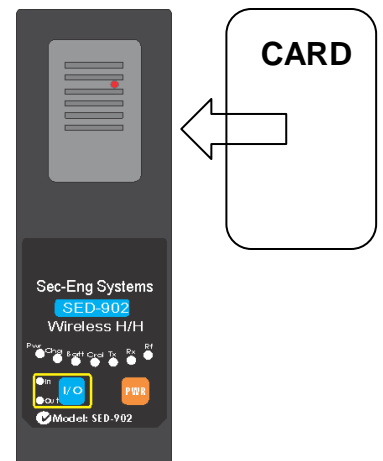

CHANGING THE RADIO CHANNEL

When there are multiple SED-902 systems operating within range of each other the radio channel used by each system can be changed to prevent an interference between them.

This can be done two ways:

- Connecting the Master to a PC via the serial port and setting this (see pages 14-15)
- By using the buttons and LEDs on the Master to set:
 1. Press and hold the PROG buttons until the Memory LED starts flashing, inducting you in Channel programming mode.

While in this mode the LEDs on the board will indicate what channel is currently selected and the TEST button will cycle between the channels.

Ch 0 = TX	■	■	POWER
Ch 1 = RX	■	■	CHARGING
Ch 2 = CTX1	■	■	LINK
Ch 3 = CRX1	■	■	MEMORY
Ch 4 = CTX2	■		
Ch 5 = CRX2	■		
Ch 6 =	■		
Ch 7 =	■		
Ch 8 =	■		
Ch 9 =	■		
Ch 10 =	■		

LEDS

Signal

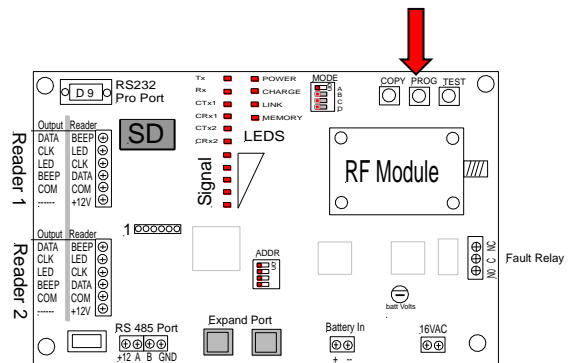

CHANNEL	FREQUENCY	CHANNEL	FREQUENCY
Ch 0	916MHz	Ch 6	922MHz
Ch 1	917MHz	Ch 7	923MHz
Ch 2	918MHz	Ch 8	924MHz
Ch 3	919MHz	Ch 9	925MHz
Ch 4	920MHz	Ch 10	926MHz
Ch 5	921MHz	Ch 11	927MHz (RESERVED)

2. Press the TEST button until the LED representing the desired channel is illuminated.
3. Press and hold the PROG button until the Memory LED goes off. This will then save the new channel selection.

Note: Once the channel has been changed you will also need to re-enroll any linked Handhelds - see page 19.

TECHNICAL SPECIFICATIONS

RADIO SPECIFICATIONS	
Type	Semtech LoRa
Frequency Operational	916MHz - 927MHz
Transmit Power	100mW
Security Encryption	By Request
Operational Range	400 meters (Line of sight)
ACCESS PROTOCOL SUPPORTED	
Wiegand	240bit (up to)
Gallagher/Cardax	GBUS (HBUS not supported)
SED-902 HANDHELD	
Battery	14V 2.34Ah Lilon
Charge Time	3 Hours
Standby Time	20 Hours
Charger Input	110V-240VAC
Charger Output	24V DC 2.5A
Reader Power	8V DC
Antenna Type	Internal – PCB
IP Rating	IP 61
Dimensions	197 x 66 x 43mm (Plastic Housing)
SED-902 MASTER	
Power Pack Input	230V-240VAC
Power Pack Output	16V AC 1.5A
External Power Supply	12V or 24V DC 2.5A
Backup Battery	12V 7Ahr gel cell (Not included)
Antenna Connection	TNC Female
Antenna Type	External 3dB Omni (High Gain Optional)
Dimensions	235 x 250 x 80mm(Metal Cabinet)
SED-902 EXPANDER	
Power Input	Supplied by Master via RS485 link
Antenna connection	Not applicable
Dimensions	235 x 250 x 80mm (Metal Cabinet)
CERTIFICATION	
FCC (FCC Identifier 2ASK9-MX001W4814) MAY 2019	

FCC IDENTIFIER: 2ASK9-MX001W4814
Name of Grantee: Sec-Eng Systems Pty Ltd.
Equipment Class: Digital Transmission System
Notes: Sed Lawra-R1
Modular Type: Single Modular

