



SED-VTI

April 2020, V1.2

Virtual Telephone Interface Installation & User Manual

**WARNING: PLEASE READ
INSTALLATION INSTRUCTIONS
FIRST**

PRODUCT WARRANTY

This product is covered by a 12 month, back to base warranty from date of purchase and proof of purchase should be supplied. The warranty does not cover damage that has resulted from the improper installation or improper use of this product. The warranty does not cover lightning damage, product misuse, electrical surges or acts of God.

LIMITATION OF LIABILITY

Sec-Eng Systems Pty Ltd does not accept any liability for the loss or damage to property or persons in relation to goods supplied. This disclaimer is only limited to the warranty of the goods supplied and the intended use.

NOTE: THIS MANUAL IS SUBJECT TO COPYRIGHT ©

OVERVIEW DIAGRAM

**MODEL: SED-VTI
BY SEC-ENG SYSTEMS**

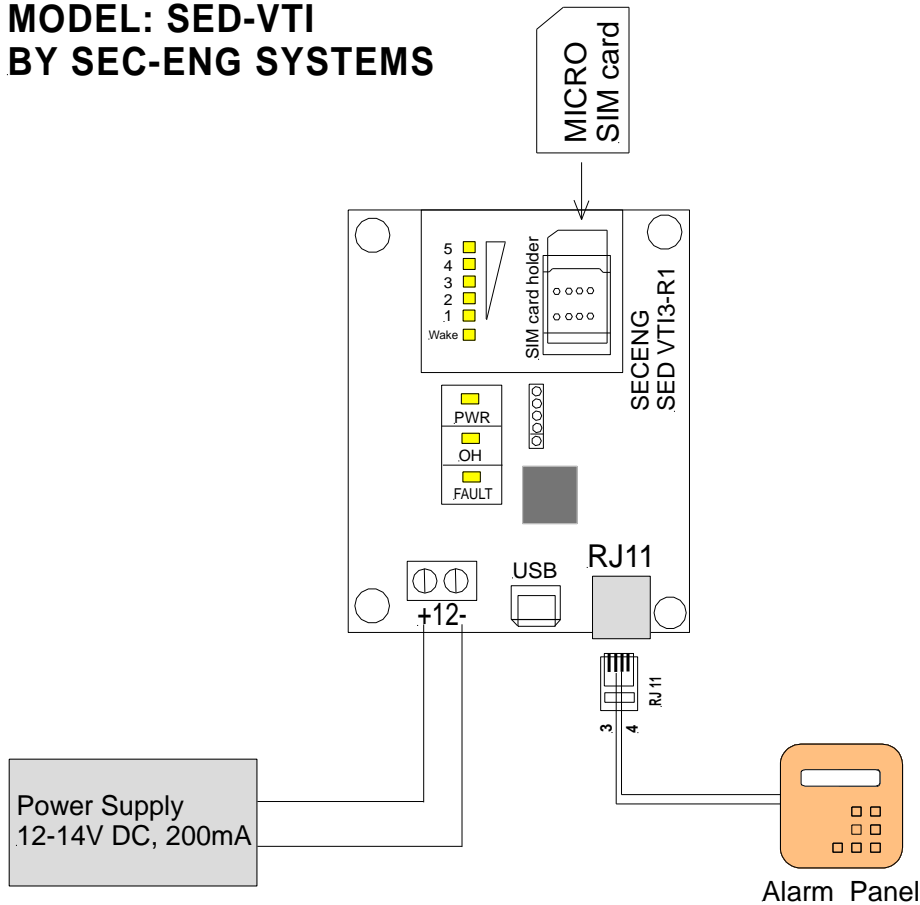

WIRING AND TERMINATION

- +12- Power in (12V DC, 200mA)
- RJ11 Line out (Connect to alarm panel)
- USB Serial port (Programming)

CHECKING SIM CARD OPERATION

The unit requires a MICRO size SIM card to operate.

Before fitting into the SED-VTI ensure that the SIM is active and not pin locked.

This may require the SIM to be tested in a mobile phone first.

If the SIM PIN request is set, it must be disabled (using a mobile phone) before it can be used in the SED-VTI.

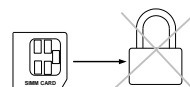

Warning: Ensure you have the correct PIN number. Entering the wrong PIN will PUK lock the SIM which will then need to be returned to the vendor for reprogramming.

WARNING

- The SED-VTI is only to be installed by an authorised service person.
- The unit requires a power supply, 12-14V DC, 200mA.
- Ensure the unit is mounted in a safe & secure location, with the antenna in an **UPRIGHT** position.
- When installing in exposed areas, ensure that the antenna is covered in 20mm conduit to prevent tampering.

The above points should be taken seriously. Failing to abide by these may result in the product not performing as designed.

INSTALLATION

1. Install the unit at least 1 meter away from the alarm panel.
2. Fit the Sec-Eng Systems supplied antenna.
3. Fit SIM card. See page 2 for instruction on SIM type and checks.
4. Power up the unit with 12-14V DC from alarm panel.
5. Once the system is ready, the PWR LED should be on constant (not flashing) and signal level LEDs showing at least 2 bars.
6. Connect the phone lead from the panel to the RJ connector on the SED-VTI.
7. Check the alarm panel is programmed with the phone number to dial (SED-VTI only provides the phone line and doesn't require any programming).

TESTING

1. Plug a test telephone into the RJ connector of the SED-VTI and ensure you can make a phone call (dial the receiver number).
2. Remove the test phone and connect the panel to the RJ port.
3. Trigger the panel to dial out. The OH LED should turn on when the line is being used.
4. When phone call is completed the OH LED should turn off.

LED INDICATION

1-5	Signal strength	5			
FAULT	System fault	4			
OH	Hook indicator	3			
PWR	Power status	2			
		1			
	Modem on indicator				

FAULT GUIDE

FAULT	ON = System/connection issue	5			
OH	ON = Line off hook	4			
PWR	ON (steady) = System ready	3			
	Flashing = Power in is low	2			
		1			

If FAULT LED is flashing, check for the following:

- SIM card is active, not PIN locked
- SIM card is fitted correctly (Chip side facing down, notched end toward outside of board)
- Antenna is fitted correctly
- Good 3G mobile signal is available at location

NOTE: Upon a power up the VTI, the Fault LED will flash until a network connection is established . This will occur within 30-60seconds. If not check for the fault conditions above.

For further assistance contact Sec-Eng Systems technical support.

SMS AND SERIAL COMMANDS

The SED-VTI has the ability to provide status, history information and settings adjustment via SMS or the USB port on the board. SMS the following commands to the phone number of the sim card fitted in the unit, or type the commands in to a terminal software (Ucon) on the PC connected to the USB port.

Status Report:

?S

SED VTI-R3: Rev 0001
 Asset: New Device
 3G: Telstra Mobile, Sig 3
 IP Address: 10.100.94.75
 GPS: Location fixed
 Vin: 11.6 V, Good
 Poll: 30 sec

Default:

?DEFAULT

This command will restore all device defaults.

REBOOT:

?BOOT

This command will remotely reboot the device.

History Report:

?H

History records 10 to 0

Phone Settings:

?PHONE

Dial Wait:	3sec (Default)	Range: 3 -10sec
Call Timer:	20min (Default)	Range: 5-120mins

PHONE SETTINGS

Dial Wait – Sets the time allowance during dialling process between each button press before the system dials out.

This can be set with the command: **button delay xx** (xx is time in seconds)

Call timer – Set the maximum duration for a call. As time expires the SED-VTI will force the call to end.

This can be set with the command: **call timer xx** (xx is time in minutes).

TECHNICAL SPECIFICATIONS

Dimensions:	110 x 95 x 30mm (Housing)
SIM Required:	MICRO size, Voice and SMS
Power input:	12-14V DC, 200mA
Line voltage:	48V
POTS interface:	RJ12
USB Port:	Mini USB
Antenna connector:	SMA Female
Antenna supplied:	3dBi Omni directional
Modem:	UBLOX Lisa-U200
Network Connectivity:	Penta-Band GSM & 3G 800/850/900/1700/1900/2100MHz

CERTIFICATION

PTCRB, GCF, R&TTE & CE (Europe), FCC (US), IC (Canada), Giteki (Japan), A-tick & RCM (Australia), IDA (Singapore), Anatel (Brazil), NCC (Taiwan), CCC (China), KCC (S. Korea), AT&T (USA), DoCoMo, Softbank (Japan), Telstra (Australia), Vodafone (All Vodafone networks), Telecom NZ, Rogers, Bell Mobility, Telus (Canada), SKT (S. Korea), ICASA (S. Africa), AT&T (US).

ACMA - RCM Certified



TECHNICAL SUPPORT

Contact Sec-Eng Systems for technical support

Phone 02-9524 9952

Mon – Fri 9.00AM to 5.00PM AEST

WWW.SECENG.COM.AU